



PRODUCTS THAT ARE SETTING WORLD RECORDS

GODFATHER CAR AMPLIFIERS

GF-15001D

GF-20001D

GF-35001D

GF-10002D

GF-2004D

GF-5004D

HIGH PERFORMANCE CAR AMPLIFIER

Before You begin installation

Before you begin , you will need tools, supplies and adapters. It is best to make sure you have everything you need before you start.

Amplifier Location

Allow air circulation around the amplifier.
 The amplifier's compact design allows greater flexibility in mounting. it can be mounted under the seat and in the trunk.
 When selecting a location, remember that amplifiers generate heat. Select a location where air can circulate around the amplifier.
 Do not cover the amplifier with carpets or enclose it behind interior trim panels.
 Every installation will be a bit different based upon vehicle design, check all locations and placements carefully before making any cuts or connections.

Disconnect Battery

Before you begin, always disconnect the battery negative terminal.

! Important:

If wiring connections are made incorrectly the unit will not operate properly and could be damaged. Follow the installation instructions carefully or have the amplifier installed by an authorized dealer.

Things to remember when installing your GODFATHER SERIES car amplifiers.

The design philosophy of **GODFATHER SERIES** car amplifiers and mode of regulation requires that proper installation and load impedance instructions be adhered to at all times.
 Minimum impedance recommended for GF-1500.1D, GF-2000.1D and GF-3500.1D are 1ohm.
 Minimum impedance recommended for GF-1000.2D, GF-200.4D and GF-500.4D is 2ohm stereo or 4ohm mono.

All **GODFATHER SERIES** car amplifiers are not equipped with fuses.

Pls use external fuses for all **GODFATHER SERIES** car amplifiers.

External fuse ratings are 140A for GF-1500.1D, 200A for GF-2000.1D, 300A for GF-3500.1D, 100A for GF-1000.2D, 60A for GF-200.4D and 130A for GF-500.4D.

These fuse ratings should be sufficient under normal working conditions. However, if the amplifiers are overloaded (see minimum impedance above) fuses may blow.

Therefore, please try to avoid operating the amplifiers under these conditions.

1. Mount the amplifiers where air flow is the best.
2. Mount the amplifiers to a solid surface away from vibration, as these amplifiers are heavy and the vibration can damage the amplifiers.
3. Take extreme caution when mounting the amplifiers, so as not to damage the chassis with a drill or screwdriver.
4. Run 4AWG (GF-1500.1D, GF-1000.2D, GF-200.4D & GF-500.4D) or 0AWG (GF-2000.1D & GF-3500.1D) wire from the battery, using fuses with 12" of the positive battery terminal.
 The fuse is to protect the car and your car audio system from the fire that could be caused by a short circuit.

5. Run 4AWG (GF-1500.1D, GF-1000.2D, GF-200.4D and GF-500.4D) or 0AWG (GF-2000.1D & GF-3500.1D) ground wire as short as possible, to the closest chassis ground point. Be sure to remove the paint around the chassis ground point to provide a more solid electrical connection.
6. Run a 16 AWG (or larger) wire to the remote turn-on lead of the headunit.
7. Connect the speakers as per wiring diagrams in the manual.
 12AWG or larger speaker wire is recommended.
8. Mount remote level control in the car where it can be easily reached from the driver's seat, if desired.
9. Using RCA interconnect cables, connect all line inputs per the wiring diagrams which follow.
 If possible, keep rca cables away from the 12V power and ground wire.
10. Set the controls as described on following pages.

Power, Remote, Ground Connection.

Power Terminal (+12V)

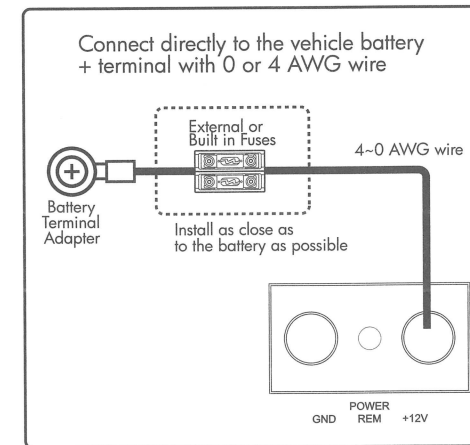

Ground Terminal (GND)

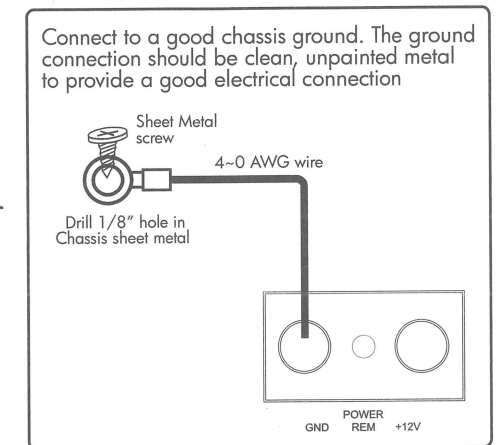

Remote / Turn on Terminal

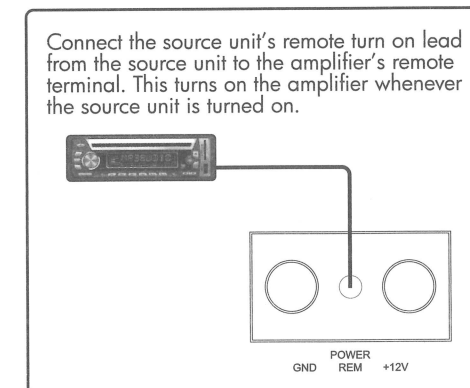

Fuses

GODFATHER SERIES car amplifiers need external fuses. Please follow fuse rates.

GF-1500.1D	: 140A
GF-2000.1D	: 200A
GF-3500.1D	: 300A
GF-1000.2D	: 100A
GF-200.4D	: 60A
GF-500.4D	: 130A

DIGITAL MONOBLOCK INPUT & OUTPUT CONNECTION

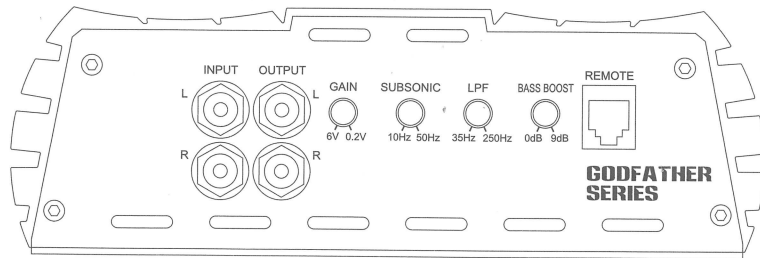

RCA INPUTS

The RCA inputs ensure the highest quality contacts and the lowest noise in your audio system.

GAIN (6V - 0.2V)

This adjusts the normal operating level of the amplifier by matching the level from the headunit.

SUBSONIC FILTER (10Hz - 50Hz)

This allows you to tune the response of the amplifier at very low frequencies.

LOW PASS FILTER (35Hz - 250Hz)

This allows you to tune the response of the amplifier at higher bass frequencies to roll off for a seamless integration into your midbass.

BASS BOOST (0 - 9dB)

This allows you to tune amplifier response with up to 9dB of boost centered at 45Hz

REMOTE CONTROL

Use this to control level of the amplifier from your driver's seat.

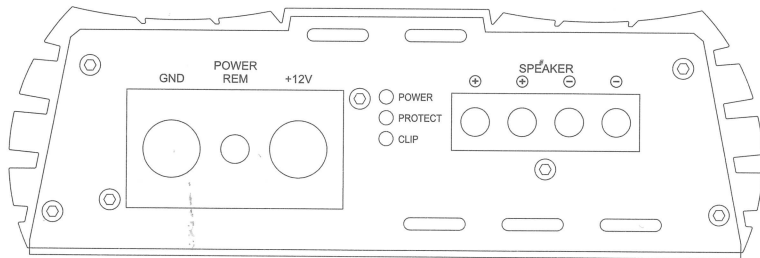

GROUND (GND) & POWER (+12V)

The power and ground will accommodate 0 or 4 AWG wire. Use high quality pure copper wire only.

REMOTE (REM)

REM connector will accept wire sizes from 12 to 18 AWG. This terminal is used to remotely turn-on and turn-off the amplifier when +12V DC is applied.

POWER & PROTECT INDICATORS -

When the unit is powered on and operating correctly the power LED illuminates.

When the unit is malfunctional or protected, then protect LED is turned on.

CLIP

When power is close to the clipping level, CLIP LED starts to clip.

As clipping level comes, Clip LED is clipping and then, finally comes to the protection in RED light on.

In order to go back normal, please reduce the gain.

SPEAKER TERMINAL BLOCK

Connect speaker cables from speaker terminal block to subwoofers.

Subwoofers impedance should be checked carefully.

DIGITAL MONOBLOCK POWER CONNECTION

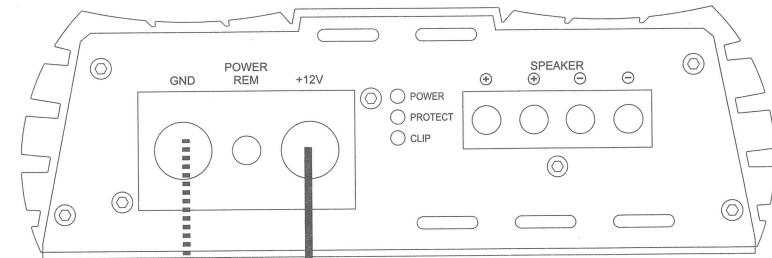

FUSE RATES

- GF-1500.1D : 140A
- GF-2000.1D : 200A
- GF-3500.1D : 300A
- GF-1000.2D : 100A
- GF-200.4D : 60A
- GF-500.4D : 130A

IMPORTANT :

WORKING VOLTAGE

- GF-1500.1D : 8.5V - 16Volts
- GF-2000.1D : 8.5V - 16Volts
- GF-3500.1D : 8.5V - 16Volts
- GF-1000.2D : 8.5V - 16Volts
- GF-200.4D : 8.5V - 16Volts
- GF-500.4D : 8.5V - 16Volts

DIGITAL MONOBLOCK SPEAKER CONNECTION

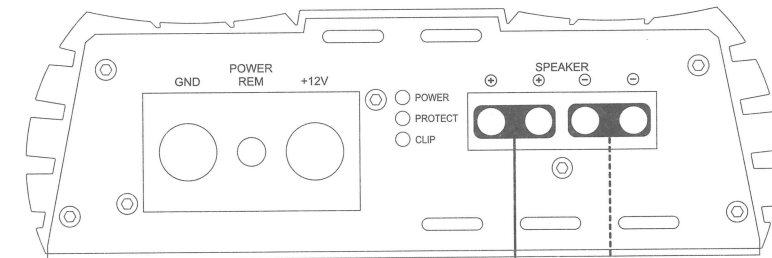

IMPORTANT :

WORKING IMPEDANCE

GF-1500.1D, GF-2000.1D & GF-3500.1D minimum impedance is 1ohm

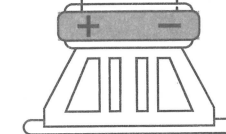

4 - 1 OHMS

FULL RANGE MULTI-CHANNEL INPUT & OUTPUT FEATURES

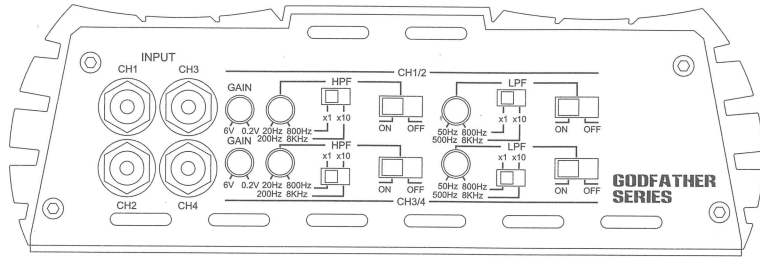

RCA INPUTS

The RCA inputs ensure the highest quality contacts and the lowest noise in your audio system.

GAIN (6V - 0.2V)

This adjusts the normal operating level of the amplifier by matching the level from the headunit.

HIGH PASS FILTER (20(200)Hz - 800(8K)Hz)

Control High pass filter frequency for the speaker output.

When setting multiply x1, then the frequencies can be adjusted from 20Hz to 800Hz.

When setting multiply x10, then the frequencies can be adjusted from 200Hz to 8KHz.

Select HPF ON/OFF switch

This allows you to tune the response of the amplifier at very low frequencies.

LOW PASS FILTER (50(500)Hz - 800(8K)Hz)

Control High pass filter frequency for the speaker output.

When setting multiply x1, then the frequencies can be adjusted from 50Hz to 800Hz.

When setting multiply x10, then the frequencies can be adjusted from 500Hz to 8KHz.

Select HPF ON/OFF switch

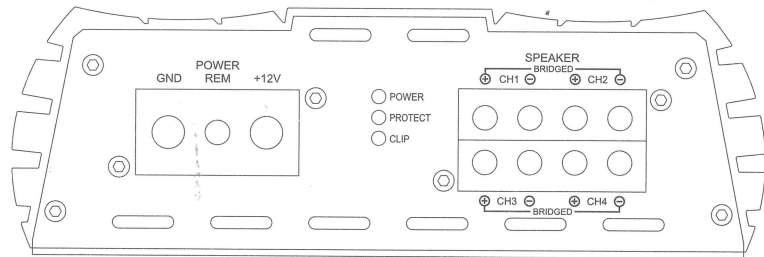

GROUND (GND) & POWER (+12V)

The power and ground will accommodate 0 or 4 AWG wire. Use high quality pure copper wire only.

REMOTE (REM)

REM connector will accept wire sizes from 12 to 18 AWG.

This terminal is used to remotely turn-on and turn-off the amplifier when +12V DC is applied.

POWER & PROTECT INDICATORS -

When the unit is powered on and operating correctly the power LED illuminates.

When the unit is malfunctional or protected, then protect LED is turned on.

CLIP

When power is close to the clipping level, CLIP LED starts to clip.

As clipping level comes, Clip LED is clipping and then, finally comes to the protection in RED light on.

In order to go back normal, please reduce the gain.

SPEAKER TERMINAL BLOCK

Connect speaker cables from speaker terminal block to subwoofers.

Subwoofers impedance should be checked carefully.

GF-1000.2D 2 CHANNEL SPEAKER CONNECTION

2 CHANNEL WIRING MODE

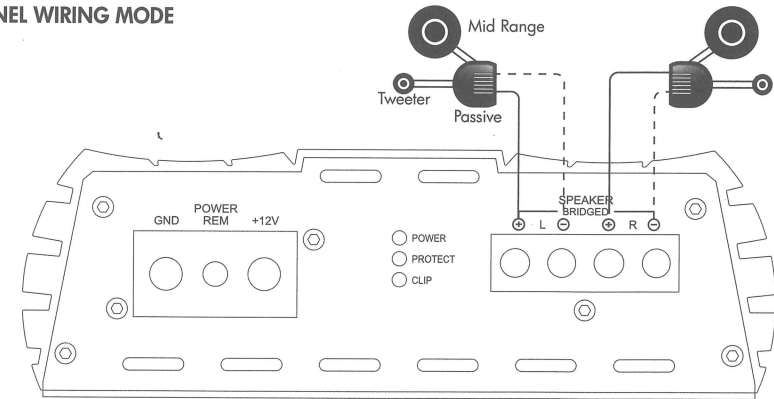

! IMPORTANT :

WORKING IMPEDANCE

GF-1000.2D minimum impedance is 2ohm stereo or 4ohm: mono

3 CHANNEL WIRING MODE

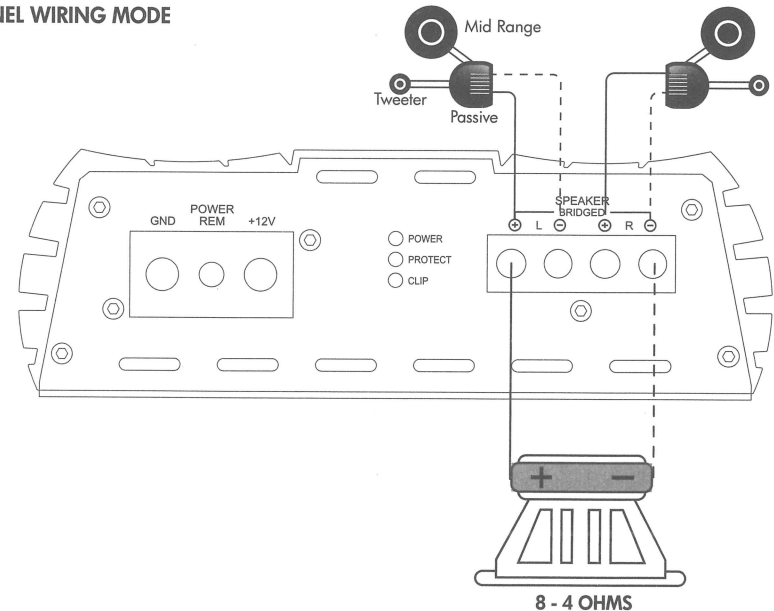

GF-200.4D & GF-500.4D 4 CHANNEL SPEAKER CONNECTION

4 CHANNEL WIRING MODE

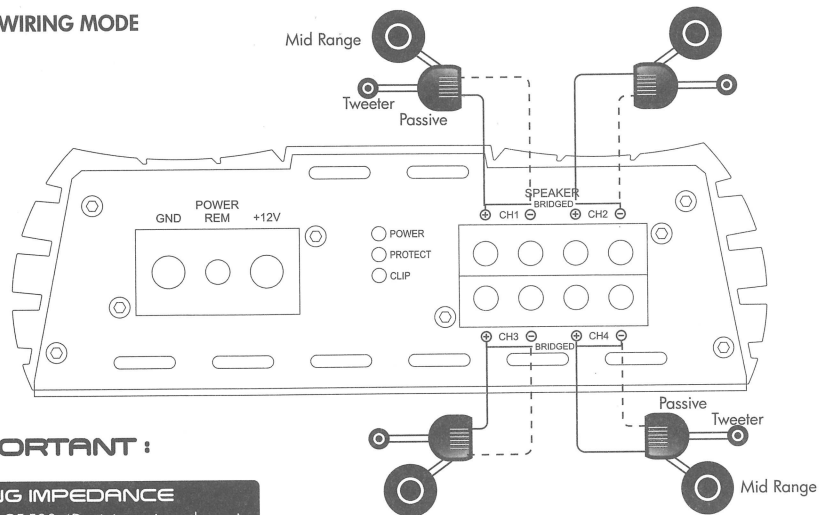

! IMPORTANT :

WORKING IMPEDANCE

GF-200.4D & GF-500.4D minimum impedance is 2ohm stereo or 4ohm mono

5 CHANNEL WIRING MODE

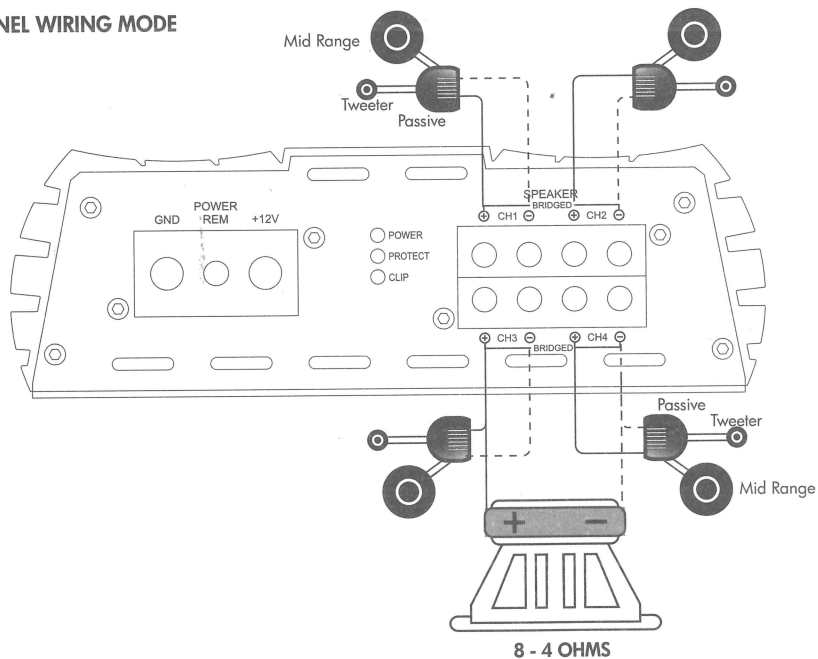

TROUBLE SHOOTING

NO POWER LED ON, NO OUTPUT

- Check +12V and GND connection
- Check remote signal +12V
- Check the external fuses or built-in.

POWER LED ON, NO OUTPUT

- Check source unit for output
- Check input gain control
- Check RCA cable
- Check speaker and wiring for shorts
- Check for damaged speakers

NO SOUND ON ONE CHANNEL

- Swap left/right input to check source
 ... If sound swaps too, source or signal cable is bad
- Swap left/right speaker to check speakers
 ... If sound does not swap, speaker or speaker wiring is bad
 ... In any case, consult authorized dealer

AMPLIFIER GOES IN PROTECTION MODE AT HIGHER GAIN

- Check speaker impedance
 GF-1500.1D, GF-2000.1D & GF-3500.1D are 1ohm.
 GF-1000.2D, GF-200.4D & GF-500.4D are 2ohm stereo or 4ohm mono.
- Check working voltages (8.5V - 16Volts)
- Check speaker wiring for short circuit

ENGINE OR ALTERNATOR WHINE NOISE

- Check wiring. make sure RCA cables are not run parallel on same side of vehicle as power cable.
- Check any preamps or black boxes in the signal path between source unit and amplifier
- Make sure ground pin (shield or outer barrel of RCA cables) have not lost connection and that source unit has good reference ground.

Features

DIGITAL MONOBLOCK AMPLIFIER

- Digital linkable/dual mono block amplifier
- Dual MOS-FET PWM power supply
- Fully stable into 1ohm
- Variable Subsonic filter
- Variable Low pass filter
- Variable Bass boost
- Wired Remote control with Clipping indicator
- Surface Mount Technology
- Multi-way protection circuitry
 (DC, Speaker Short, Thermal and Voltage)

Specifications

	GF-1500.1D	GF-2000.1D	GF-3500.1D
No of Channels	1 Channel	1 Channel	1 Channel
Configuration	Digital Mono	Digital Mono	Digital Mono
4ohm RMS power	670W	1060W	1540W
2ohm RMS power	1120W	1560W	2280W
1ohm RMS power	1508W	2340W	3047W
4ohm mono power	na	na	na
Frequency Response	10Hz - 250Hz	10Hz - 250Hz	10Hz - 250Hz
Signal to Noise Ratio	85dB	85dB	85dB
Efficiency @ 4ohm	Over 90%	Over 90%	Over 90%
Damping Factor	150 <	150 <	150 <
Input Sensitivity	6V - 0.2V	6V - 0.2V	6V - 0.2V
Subsonic Filter	10Hz - 50Hz	10Hz - 50Hz	10Hz - 50Hz
Low Pass Filter	35Hz - 250Hz	35Hz - 250Hz	35Hz - 250Hz
Multiply (x1, x10)	na	na	na
High Pass Filter	na	na	na
Multiply (x1, x10)	na	na	na
Bass Boost @45Hz	0dB - 9dB	0dB - 9dB	0dB - 9dB
THD @ 4ohm	< 0.1%	< 0.1%	< 0.1%
Fuse Rating	140A	200A	300A
Dimensions (L)	7.09 inches	10.24 inches	13.78 inches
	7.15W x 2.33H inches		

All features are subject to change in the continuing efforts to improve the products without notice.

Features

MULTI-CHANNEL AMPLIFIER

- 2ohm stereo stable full range digital circuit
- Variable High pass filter
- Variable Low pass filter
- Multiply x1, x10
- Band-pass capable
- Surface Mount Technology
- Double sided printed circuit board
- Multi-way protection circuitry
- (DC, Speaker Short, Thermal and Voltage)

Specifications

	GF-1000.2D	GF-200.4D	GF-500.4D
No of Channels	2 Channels	4 Channels	4 Channels
Configuration	Full Range digital	Full Range digital	Full Range digital
4ohm RMS power	400W x 2	110W x 4	240W x 4
2ohm RMS power	620W x 2	180W x 4	360W x 4
1ohm RMS power	na	na	na
4ohm mono power	1300W x 1	360W x 2	760W x 2
Frequency Response	10Hz - 38KHz	10Hz - 40KHz	10Hz - 34KHz
Signal to Noise Ratio	85dB	85dB	85dB
Efficiency @ 4ohm	Over 70%	Over 70%	Over 70%
Damping Factor	150 <	150 <	150 <
Input Sensitivity	6V - 0.2V	6V - 0.2V	6V - 0.2V
Subsonic Filter	na	na	na
Low Pass Filter	50Hz - 800Hz	50Hz - 800Hz	50Hz - 800Hz
Multiply (x1, x10)	500Hz - 8KHz	500Hz - 8KHz	500Hz - 8KHz
High Pass Filter	20Hz - 800Hz	20Hz - 800Hz	20Hz - 800Hz
Multiply (x1, x10)	200Hz - 8KHz	200Hz - 8KHz	200Hz - 8KHz
Bass Boost @45Hz	na	na	na
THD @ 4ohm	< 0.1%	< 0.1%	< 0.1%
Fuse Rating	100A	60A	130A
Dimensions (L)	11.82 inches	7.88 inches	11.82 inches
	7.15W x 2.33H inches		

All features are subject to change in the continuing efforts to improve the products without notice.